

NATIONAL AERONAUTICS AND SPACE ADMINISTRATION

# Deep Impact Comet Encounter

Press Kit  
June 2005

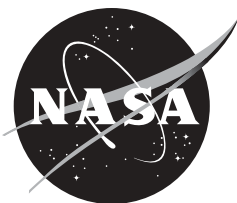

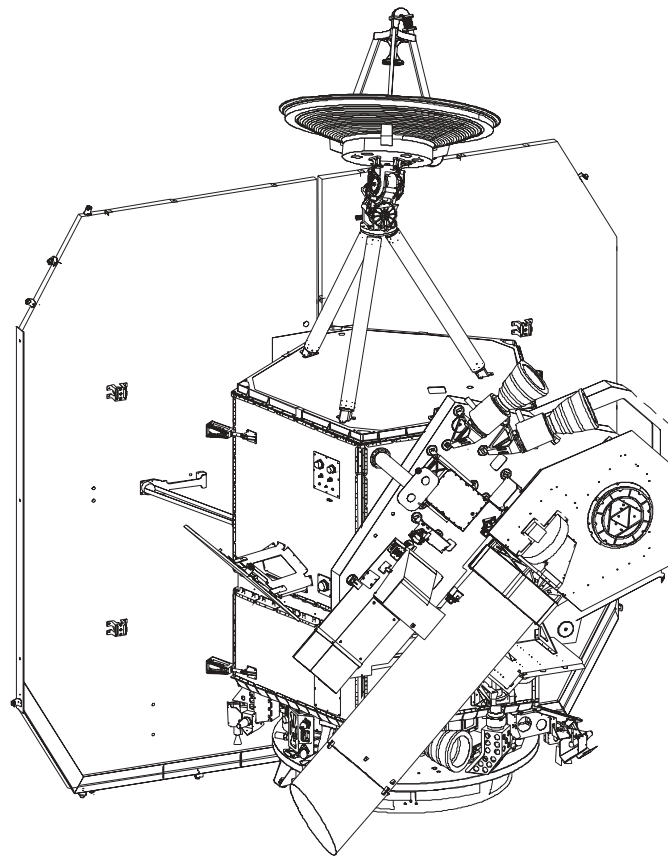

## Media Contacts

Dolores Beasley NASA Headquarters, Washington, DC	Policy/Program Management	202/358-1753
DC Agle Jet Propulsion Laboratory, Pasadena, Calif.	Deep Impact Mission	818/393-9011
Lee Tune University of Maryland, College Park, Maryland	Science Investigation	301/405-4679

## Contents

General Release .....	3
Media Services Information .....	5
Quick Facts .....	6
Why Deep Impact ?.....	7
Comet Missions .....	8
NASA's Discovery Program .....	10
Mission Overview .....	14
Encounter Events .....	19
Spacecraft .....	23
Science Objectives .....	25
Comet Cratering 101 .....	32
Program/Project Management .....	34



## **GENERAL RELEASE:**

### **NASA ANNOUNCES SPECTACULAR DAY OF THE COMET**

After a voyage of 173 days and 431 million kilometers (268 million miles), NASA's Deep Impact spacecraft will get up-close and personal with comet Tempel 1 on July 4 (EDT).

The first of its kind, hyper-speed impact between space-borne iceberg and copper-fortified probe is scheduled for approximately 1:52 a.m. EDT on Independence Day (10:52 p.m. PDT on July 3). The potentially spectacular collision will be observed by the Deep Impact spacecraft, and ground and space-based observatories.

"We are really threading the needle with this one," said Rick Grammier, Deep Impact project manager at NASA's Jet Propulsion Laboratory, Pasadena, Calif. "In our quest of a great scientific payoff, we are attempting something never done before at speeds and distances that are truly out of this world."

During the early morning hours of July 3 (EDT), the Deep Impact spacecraft will deploy a 1-meter-wide (39-inch) impactor into the path of the comet, which is about half the size of Manhattan Island, N.Y. Over the next 22 hours, Deep Impact navigators and mission members located more than 133 million kilometers (83 million miles) away at JPL, will steer both spacecraft and impactor toward the comet. The impactor will head into the comet and the flyby craft will pass approximately 500 kilometers (310 miles) below.

Tempel 1 is hurtling through space at approximately 37,100 kilometers per hour (23,000 miles per hour or 6.3 miles per second). At that speed you could travel from New York to Los Angeles in less than 6.5 minutes. Two hours before impact, when mission events will be happening so fast and so far away, the impactor will kick into autonomous navigation mode. It must perform its own navigational solutions and thruster firings to make contact with the comet.

"The autonav is like having a little astronaut on board," Grammier said. "It has to navigate and fire thrusters three times to steer the wine cask-sized impactor into the mountain-sized comet nucleus closing at 23,000 miles per hour."

The crater produced by the impact could range in size from a large house up to a football stadium, and from two to 14 stories deep. Ice and dust debris will be ejected from the crater, revealing the material beneath. The flyby spacecraft has approximately 13 minutes to take images and spectra of the collision and its result before it must endure a potential blizzard of particles from the nucleus of the comet.

"The last 24 hours of the impactor's life should provide the most spectacular data in the history of cometary science," said Deep Impact Principal Investigator Dr. Michael

A'Hearn of the University of Maryland, College Park. "With the information we receive after the impact, it will be a whole new ballgame. We know so little about the structure of cometary nuclei that almost every moment we expect to learn something new."

The Deep Impact spacecraft has four data collectors to observe the effects of the collision. A camera and infrared spectrometer, which comprise the High Resolution Instrument, are carried on the flyby spacecraft, along with a Medium Resolution Instrument. A duplicate of the Medium Resolution Instrument on the impactor will record the vehicle's final moments before it is run over by Tempel 1.

"In the world of science, this is the astronomical equivalent of a 767 airliner running into a mosquito," said Dr. Don Yeomans, a Deep Impact mission scientist at JPL. "The impact simply will not appreciably modify the comet's orbital path. Comet Tempel 1 poses no threat to the Earth now or in the foreseeable future."

Deep Impact will provide a glimpse beneath the surface of a comet, where material from the solar system's formation remains relatively unchanged. Mission scientists expect the project will answer basic questions about the formation of the solar system, by offering a better look at the nature and composition of the frozen celestial travelers we call comets.

The University of Maryland is responsible for overall Deep Impact mission management, and project management is handled by JPL. The spacecraft was built for NASA by Ball Aerospace & Technologies Corporation, Boulder, Colo.

For more information about Deep Impact on the Internet, visit:

**<http://www.nasa.gov/deepimpact>**

For information about NASA and agency programs on the Internet, visit:

**<http://www.nasa.gov/home/index.html>**

- End of General Release -

# Media Services Information

## NASA Television Transmission

As of July 1, 2005, NASA Television will be carried on an MPEG-2 digital signal accessed via satellite AMC-6, at 72 degrees west longitude, transponder 17C, 4040 MHz, vertical polarization. For those in Alaska or Hawaii, NASA Television will be seen on AMC-7, at 137 degrees west longitude, transponder 18C, at 4060 MHz, horizontal polarization. In both instances, a Digital Video Broadcast (DVB)-compliant Integrated Receiver Decoder (IRD) will be needed for reception. The schedule for Deep Impact mission television coverage is available on the NASA Television website, at [www.nasa.gov/ntv](http://www.nasa.gov/ntv) .

## Media Credentialing

Journalists who wish to cover the events surrounding Deep Impact's encounter with comet Tempel 1 at the Jet Propulsion Laboratory should contact the JPL Media Relations Office by close of business on June 15, 2005, to arrange for advance credentials. Journalists who do not apply by June 15 may apply in person at the JPL Visitor Center between June 27 and July 1 on a first-come, first-served basis. In-person applications are subject to delay depending on the volume of requests. All media must have valid photo identification. Non-U.S. citizens must also bring their passport and visa.

Journalists who hold a 2004 JPL press badge (yellow badge) may renew it for 2005 by sending two passport-sized photographs by June 15 to Media Accreditation, Mail Stop 186-120, Jet Propulsion Laboratory, 4800 Oak Grove Dr., Pasadena, Calif. 91109. Accreditation questions should be directed to the media relations office at 818-354-5011.

## Briefings

A mission overview news briefing will be held at NASA Headquarters on June 9, 2005, at 1 p.m. EDT.

A pre-encounter briefing will be held at NASA's Jet Propulsion Laboratory on Friday, July 1 at 10 a.m. PDT. A second pre-encounter briefing will be held at JPL on Sunday, July 3. A post-encounter briefing is scheduled for JPL the morning of July 4.

All briefings will be carried live on NASA Television.

## Internet Information

News and information on the Deep Impact mission, including an electronic copy of this press kit, news releases, fact sheets, status reports and images, are available from the NASA website at [www.nasa.gov/deepimpact](http://www.nasa.gov/deepimpact) .

Detailed background information on the mission is available from the Deep Impact project home page at [deepimpact.jpl.nasa.gov](http://deepimpact.jpl.nasa.gov) .

# Quick Facts

## **Flyby Spacecraft**

Dimensions: 3.3 meters (10.8 feet) long, 1.7 meters (5.6 feet) wide, and 2.3 meters (7.5 feet) high

Weight: 601 kilograms (1,325 pounds) at launch, consisting of 515 kilograms (1,135 pounds) spacecraft and 86 kg (190 lbs) fuel

Power: 2.8-meter-by-2.8-meter (9-foot-by-9 foot) solar panel providing up to 750 watts, depending on distance from Sun. Power storage via small 16-amp-hour rechargeable nickel hydrogen battery

## **Impactor**

Dimensions: 1 meter (39 inches) long, 1 meter (39 inches) in diameter

Weight: 372 kilograms (820 pounds) at launch, consisting of 364 kilograms (802 pounds) spacecraft and 8 kilograms (17 pounds) of fuel

Power: Non-rechargeable 250-amp-hour battery

## **Comet Tempel 1**

Nucleus shape: Elongated, irregular

Nucleus size (estimated): 14 by 4.6 by 4.6 kilometers (9 by 3 by 3 miles)

Nucleus mass: Unknown; possibly about 1 trillion kilograms (roughly 1 billion tons)

Nucleus rotation period: About 41.85 hours

Nucleus composition: Theory and observations of other comets suggest silicate dust (~25%), organics (~25%), ices (40%), other material (10%)

## **Mission**

Launch: Jan. 12, 2005

Launch site: Cape Canaveral Air Force Station, Florida

Launch vehicle: Delta II 7925 with Star 48 upper stage

Earth-comet distance at time of launch: 267 million kilometers (166 million miles)

Comet impact: 1:52 a.m. EDT July 4, 2005 (time subject to adjustment)

Earth-comet distance at time of impact: 133.6 million kilometers (83 million miles)

Total distance traveled by spacecraft from Earth to comet: 431 million kilometers (268 million miles)

Closing speed of impactor relative to comet nucleus at time of impact: 37,100 kilometers per hour (23,000 miles per hour)

End of mission: Aug. 3, 2005 (30 days after impact)

## **Program**

Cost: \$333 million total (including launch vehicle)

# Why Deep Impact?

Out beyond the orbits of the planets on the outer fringes of the solar system, a swarming belt of billions of dormant comets circles the Sun. Frozen balls of ice, rocks and dust, they are the undercooked leftovers that remained after a sprawling cloud of gas and dust condensed to form the Sun and planets about 4.6 billion years ago. From time to time, the gravitational pull of other comets or the giant outer planets will nudge some of them out of their orbits, plunging them into the inner solar system, where they erupt with sparkling tails as they loop around the Sun.

One of these nomadic frozen ice balls is the target for NASA's Deep Impact mission. On July 4, 2005, Deep Impact will produce a crater on the surface of comet Tempel 1 that could range in size from a two-bedroom house to the Roman Coliseum. The impact is expected to eject ice and dust from the surface of the crater and reveal untouched, primordial material beneath. While this is happening, the spacecraft's cameras will radio images to Earth of the comet's approach, impact and aftermath.

Data returned from the Deep Impact spacecraft could provide opportunities for significant breakthroughs in our knowledge of how the solar system formed, the makeup of cometary interiors, and the role that cometary impacts may have played with Earth's early history and the beginning of life.

## Comets

Though frequently beautiful, comets traditionally have stricken terror as often as they have generated wonder as they arc across the sky during their passages around the Sun. Astrologers interpreted the sudden appearances of the glowing visitors as ill omens presaging famine, flood or the death of kings. Even as recently as the 1910 appearance of Halley's Comet, entrepreneurs did a brisk business selling gas masks to people who feared Earth's passage through the comet's tail.

In the 4th century B.C., the Greek philosopher Aristotle concluded that comets were some kind of emission from Earth that rose into the sky. The heavens, he maintained, were perfect and orderly; a phenomenon as unexpected and erratic as a comet surely could not be part of the celestial vault. In 1577, Danish astronomer Tycho Brahe carefully examined the positions of a comet and the Moon against the star background. Using observations of the comet made at the same time from two different locations, Tycho noted that both observers saw the comet nearly in the same location with respect to the background stars. If the comet was closer than the moon, this would not have been the case. This so-called parallax effect can be demonstrated if you hold up a finger and look at it while closing one eye and then the other. Tycho concluded that the comet was at least six times farther away than the moon.

## Comet Missions

Comets have been studied by several spacecraft, not all of which were originally designed for that purpose. Several new missions to comets are being developed for launch in coming years.

Past cometary missions include:

- ❑ In 1985, NASA modified the orbit of the International Sun-Earth Explorer spacecraft to execute a flyby of Comet 21P/Giacobini-Zinner. At that point, the spacecraft was renamed **International Comet Explorer**. It successfully flew through the tail of comet Giacobini-Zinner in 1985 and flew past comet 1P/Halley in 1986.
- ❑ An international armada of robotic spacecraft flew out to greet Halley's Comet during its return in 1986. The fleet included the European Space Agency's **Giotto**, the Soviet Union's **Vega 1** and **Vega 2**, and Japan's **Sakigake** and **Suisei** spacecraft.
- ❑ Comet Shoemaker-Levy 9's spectacular collision with Jupiter in 1994 was observed by NASA's **Hubble Space Telescope**, the Jupiter-bound **Galileo** spacecraft and the Sun-orbiting **Ulysses** spacecraft.
- ❑ **Deep Space 1** launched from Cape Canaveral on October 24, 1998. During a highly successful primary mission, it tested 12 advanced, high-risk technologies in space. In an extremely successful extended mission, it encountered comet 19P/Borrelly and returned the best images and other scientific data taken from a comet up to that time.
- ❑ The **Comet Nucleus Tour**, or **Contour**, mission launched from Cape Canaveral on July 3, 2002. Six weeks later, on August 15, contact with the spacecraft was lost after a planned maneuver that was intended to propel it out of Earth orbit and into its comet-chasing solar orbit.

Other active cometary missions are:

- ❑ NASA's **Stardust** mission flew within 236 kilometers (about 147 miles) of the nucleus of comet 81P/Wild 2 on Jan. 2, 2004. Its flight path took it through the comet's inner coma, the glowing cloud that surrounds the comet nucleus. The flyby yielded the most detailed, high-resolution comet images ever, revealing a rigid surface dotted with towering pinnacles, plunging craters, steep cliffs, and dozens of jets spewing material into space. Launched in 1999, the Stardust spacecraft is headed back to Earth with its payload of thousands of captured particles. The spacecraft's sample return capsule is scheduled to make a soft landing in the Utah desert in January 2006.
- ❑ A European Space Agency mission, **Rosetta**, was launched March 2, 2004 to orbit comet 67P/Churyumov-Gerasimenko and deliver a scientific package to its surface via a lander in 2014. NASA provided scientific instruments for the cometary orbiter.

A hundred years later, the English physicist Isaac Newton established that a comet appearing in 1680 followed a nearly parabolic orbit. The English astronomer Edmond Halley used Newton's method to study the orbits of two dozen documented cometary visits. The orbits of three comets seen in 1531, 1607 and 1682 were so similar that he concluded they in fact were appearances of a single comet wheeling around the Sun in a closed ellipse every 75 years or so. He successfully predicted the next visit in 1758-9, and the comet thereafter bore his name.

Since then, astronomers have concluded that some comets return relatively frequently, in intervals ranging from 3 to 200 years; these are called "short-period" comets. Others have enormous orbits that bring them back only once in hundreds of millennia.

In the mid-1800s, scientists also began to turn their attention to the question of comets' composition. Astronomers noted that several major meteor showers took place when Earth passed through the known orbits of comets, leading them to conclude that the objects are clumps of dust or sand. By the early 20th century, astronomers studied comets using the technique of spectroscopy, breaking down the color spectrum of light given off by an object to reveal the chemical makeup of the object. They concluded that comets also emitted gases and molecular ions in addition to the grains of dust.

In 1950, the American astronomer Fred L. Whipple (1906-2004) authored a major paper proposing what became known as the "dirty snowball" model of the cometary nucleus. This model, which has since been widely adopted, pictures the nucleus as a mixture of dark organic material, rocky grains and water ice. ("Organic" means that the compound is based on carbon and hydrogen, but is not necessarily biological in origin.) Most nuclei of comets range in size from about 1 to 10 kilometers (1/2 to 6 miles) in diameter.

If comets contain icy material, they must originate somewhere much colder than the relatively warm inner solar system. In 1950, the Dutch astronomer Jan Hendrik Oort (1900-1992) used indirect reasoning from observations to predict the existence of a vast cloud of comets orbiting many billions of miles from the Sun -- perhaps 50,000 astronomical units (AU) away (one AU is the distance from Earth to the Sun), or nearly halfway to the next nearest star. This region has since become known as the Oort Cloud.

A year later, the Dutch-born American astronomer Gerard Kuiper (1905-1973) pointed out that there should be comet-like objects remaining in the outer planetary region after the solar system formation process was complete.. He suggested the existence of a belt of dormant comets lying just outside the orbits of the planets at perhaps 30 to 100 AU from the Sun; this has become known as the Kuiper Belt. (Other astronomers such as Frederick Leonard and Kenneth Edgeworth also speculated about the existence of such a belt in the 1930s and 1940s, and so the region is sometimes referred to as the Edgeworth-Kuiper Belt, the Leonard-Edgeworth-Kuiper Belt, and so on.) The Kuiper Belt is now known to be the source of those comets with relatively short orbital

## NASA's Discovery Program

Deep Impact is the eighth mission in NASA's Discovery Program, which sponsors frequent, cost-capped solar system exploration missions with highly focused scientific goals. Created in 1992, the Discovery Program competitively selects proposals submitted by teams led by scientists, supported by organizations that manage the project, as well as partners that build and fly the spacecraft. In recent years, NASA has identified several finalists from dozens of mission proposals submitted. These finalists receive funding to conduct feasibility studies for an additional period of time before a final selection is made.

Other missions in the Discovery Program are:

- ❑ The **Near Earth Asteroid Rendezvous** spacecraft (later renamed **Near Shoemaker**) was launched Feb. 17, 1996 and became the first spacecraft to orbit an asteroid when it reached Eros in February 2000. A year later, it became the first spacecraft to land on an asteroid when it put down on Eros, providing the highest resolution images ever obtained of an asteroid, showing features as small as one centimeter across. The mission was managed by Johns Hopkins University's Applied Physics Laboratory.
- ❑ **Mars Pathfinder** was launched Dec. 4, 1996 and landed on Mars on July 4, 1997, demonstrating a unique way of touching down with airbags to deliver a small robotic rover. Mars Pathfinder was managed by NASA's Jet Propulsion Laboratory.
- ❑ Launched Jan. 7, 1998, **Lunar Prospector** entered orbit around Earth's Moon five days later, circling at an altitude of about 100 kilometers (60 miles). The principal investigator was Dr. Alan Binder of the Lunar Research Institute, Gilroy, Calif., with project management by NASA's Ames Research Center.
- ❑ **Stardust** was launched Feb. 7, 1999. On Jan. 2, 2004, it collected samples of cometary and interstellar dust as it flew through the coma surrounding the nucleus of Comet Wild 2. The samples will be returned to Earth in January 2006 at the Utah Test & Training Range. The principal investigator is Dr. Donald Brownlee of the University of Washington, with project management by NASA's Jet Propulsion Laboratory.
- ❑ Launched Aug. 8, 2001, **Genesis** collected pristine samples of solar wind beyond the Moon's orbit. The Genesis sample return capsule entered Earth's atmosphere over the Utah Test & Training Range on Sept. 8, 2004, but its parachute system did not deploy. The mission's samples of solar wind were recovered and are currently being analyzed by scientists at NASA's Johnson Space Center. Genesis was managed by the Jet Propulsion Laboratory, with Dr. Donald Burnett of the California Institute of Technology as principal investigator.
- ❑ The **Comet Nucleus Tour** or **Contour**, launched from Cape Canaveral on July 3, 2002. Unfortunately, six weeks later, on Aug. 15, contact with the spacecraft was lost after a planned maneuver that was intended to propel it out of Earth orbit and into its comet-chasing solar orbit. Contour was managed by Johns Hopkins University's Applied Physics Laboratory, and the principal investigator was Dr. Joseph Veverka of Cornell University.
- ❑ The **Mercury Surface, Space Environment, Geochemistry and Ranging (Messenger)** mission was launched Aug. 3, 2004. Entering orbit around the planet closest

*(continued on next page)*

*(continued from previous page)*

to the Sun in September 2009, the spacecraft will produce a global map and details about Mercury's surface, interior, atmosphere and magnetosphere. The mission is managed by Johns Hopkins University's Applied Physics Laboratory, and the principal investigator is Dr. Sean C. Solomon of the Carnegie Institution.

□ The **Dawn** mission will undertake a journey in both space and time by traveling to two of the oldest and most massive asteroids in our solar system, Vesta and Ceres. Planned for launch in May 2006, the ion-propulsion-powered spacecraft will reach Vesta in 2010 and Ceres in 2014. These minor planets have existed since the earliest time of solar system formation. Dawn is managed by NASA's Jet Propulsion Laboratory, and Dr. Christopher Russell of UCLA is the principal investigator.

□ The **Kepler** mission is designed to find Earth-size planets in orbit around stars like our Sun outside of the solar system. It will survey our galactic neighborhood to detect and characterize hundreds of terrestrial and larger planets in or near the "habitable zone," defined by scientists as the distance from a star where liquid water can exist on a planet's surface. Planned for launch in fall 2007, Kepler will monitor 100,000 stars similar to our Sun for four years. Dr. William Borucki of NASA's Ames Research Center is the principal investigator, with project management by NASA's Jet Propulsion Laboratory.

periods about the sun. Close encounters with other dormant comets sometimes change their orbits so that they venture in toward the Sun and fall under the influence of the gravities of the giant outer planets -- first Neptune, then Uranus, then Saturn and finally Jupiter.

The Oort Cloud, by contrast, would be the home of long-period comets. They are periodically nudged from their orbits by any one of several influences -- perhaps the gravitational pull of a passing star or giant molecular cloud, or tidal forces of the Milky Way Galaxy.

In addition to the length of time between their visits, another feature distinguishes short- and long-period comets. The orbits of short-period comets are all fairly close to the ecliptic plane, the plane in which Earth and most other planets orbit the Sun. Long-period comets, by contrast, dive inwards toward the Sun from virtually any part of the sky. This suggests that the Kuiper Belt is a relatively flat belt, whereas the Oort Cloud is a three-dimensional sphere surrounding the solar system.

Where did the Oort Cloud and Kuiper Belt come from? Most astronomers now believe that the material that became comets condensed in the outer solar system around the orbits of Uranus and Neptune and beyond. Gravitational effects from those giant planets flung some of the comets outward to the Oort cloud, while the comets in the Kuiper Belt may have remained there.

Residing at the farthest reaches of the Sun's influence, comets did not undergo the

same heating as the rest of the objects in the solar system, so they retain, largely unchanged, the original composition of solar system materials. As the preserved building blocks of the outer solar system, comets offer clues to the chemical mixture from which the planets formed some 4.6 billion years ago.

The geologic record of the planets shows that, about 3.9 billion years ago, a period of heavy cometary and asteroidal bombardment tapered off. The earliest evidence of life on Earth dates from just after the end of this heavy bombardment. The constant barrage of debris had vaporized any water on Earth, leaving the planet too hot for the survival of the fragile carbon-based molecules upon which life is based. Scientists therefore wonder: How could life form so quickly when there was so little liquid water or carbon-based molecules on Earth's surface? The answer may be that comets, which are abundant in both water and carbon-based molecules, delivered essential ingredients for life to begin.

Comets are also at least partially responsible for the replenishment of Earth's oceans after the vaporization of an early ocean during the late heavy bombardment. While Earth has long been regarded as the "water planet," it and the other terrestrial planets (Mercury, Venus and Mars) are actually poor in the percentage of water ice and in carbon-based molecules they contain when compared to objects that reside in the outer solar system at Jupiter's orbit or beyond. Comets are about 50 percent water by weight and about 10 to 20 percent carbon by weight. It has long been suspected that what little carbon and water there is on Earth was delivered here by objects such as comets that came from a more water-rich part of the solar system.

While comets are a likely source for life's building blocks, they have also played a devastating role in altering life on our planet. A comet or asteroid is credited as the likely source of the impact that changed Earth's climate, wiped out the dinosaurs and gave rise to the age of mammals 65 million years ago.

### **Right Place, Right Time, Right Snowball**

The Deep Impact mission's target, Comet 9P/Tempel 1, was discovered on April 3, 1867 by Ernst Wilhelm Leberecht Tempel, then living in Marseilles, France, while visually searching for comets. It was the ninth periodic comet to be recognized as such. Tempel 1 is a short-period comet -- meaning that it moves about the Sun in an elliptic orbit between the planets Mars and Jupiter. In Tempel 1's case that is once every 5.5 years. Its nucleus is believed to be of low density, with a diameter of about 6.5 kilometers (about 4 miles). Earth-based observations indicate it makes one full rotation about its axis about every 41 hours.

Like other short-period comets, Tempel 1 has an orbit fairly close to the ecliptic plane. The orbit slices through that plane at a reasonable distance from the Sun and Earth, making Tempel 1 well-placed for an intercept.

## **Mechanics of Deep Impact's 'Impact'**

Deep Impact's flyby spacecraft literally drops off the impactor in a position to be hit by the comet.

The spacecraft's impactor will collide with comet 9P/Tempel 1 when the comet is near its perihelion, or the closest point to the Sun in its orbit. The 372-kilogram (820-pound) impactor will be "run over" by the comet with a closing velocity between comet and impactor of 10.3 kilometers per second (about 23,000 miles per hour). This will change the comet's velocity by 0.0001 millimeter per second (about 0.014 inch per hour). It will decrease the comet's perihelion distance (the closest it gets to the Sun) by 10 meters (about 33 feet), and decrease its orbital period by far less than one second of time. The net impact on the comet's motion will be undetectable -- the astronomical equivalent of a mosquito running into a 767 airliner.

By comparison, when the comet passes by Jupiter in 2024, its perihelion distance will change by 34 million kilometers (about 21 million miles). In other words, the changes in the motion of comet Tempel 1 caused by Deep Impact are completely negligible when compared to the comet's orbital changes as it passes by Jupiter.

# Mission Overview

A daring mission offering great scientific payoff, Deep Impact is the first spacecraft ever to attempt impact with a cometary nucleus in an effort to probe and discover the secrets that lie beneath its surface. The mission is a tremendous technological challenge -- the equivalent of hitting a bullet with a bullet, while taking a picture from a third bullet flying by. Launched in January 2005, Deep Impact will fly directly to its encounter with comet Tempel 1, making no planetary flybys along the way. The voyage will take about six months.

The mission has been designed as the most expedient way to accomplish the project's primary scientific objective -- to observe close-up the internal structure and composition of a comet. The mission is part of NASA's Discovery program, aimed at launching many small, relatively low-cost missions that perform focused science with fast turn-around times, and are joint efforts with industry, small business and universities.

## Mission Phases

Six mission phases have been defined to simplify descriptions of the different periods of activity during the mission. These are the launch, commissioning, cruise, approach, encounter and playback phases.

### Launch

Deep Impact was launched Jan. 12, 2005, from Space Launch Complex 17B at Cape Canaveral Air Station. The launch vehicle was a variant of the Delta II known as a Delta 7925. This version of the Delta II uses a first-stage rocket with nine solid-fuel boosters and a second-stage rocket with a restartable engine. It was topped by a Star 48 solid-fuel upper-stage booster that provided the final kick to send Deep Impact on its way toward comet Tempel 1.

### Commissioning Phase

The first weeks after launch was a time of initial operation, checkout and calibration for the spacecraft and payload. During this phase, the mission team verified the basic state of health of all subsystems and tested the operation of science instruments. The spacecraft's autonomous navigation system was activated and tested using the moon and Jupiter as targets. A trajectory correction maneuver was performed, refining the spacecraft's flight path to comet Tempel 1.

### Cruise Phase

The cruise phase began 30 days after launch and ended 60 days before the cometary encounter. As the spacecraft flies toward the comet, the mission team conducted sci-

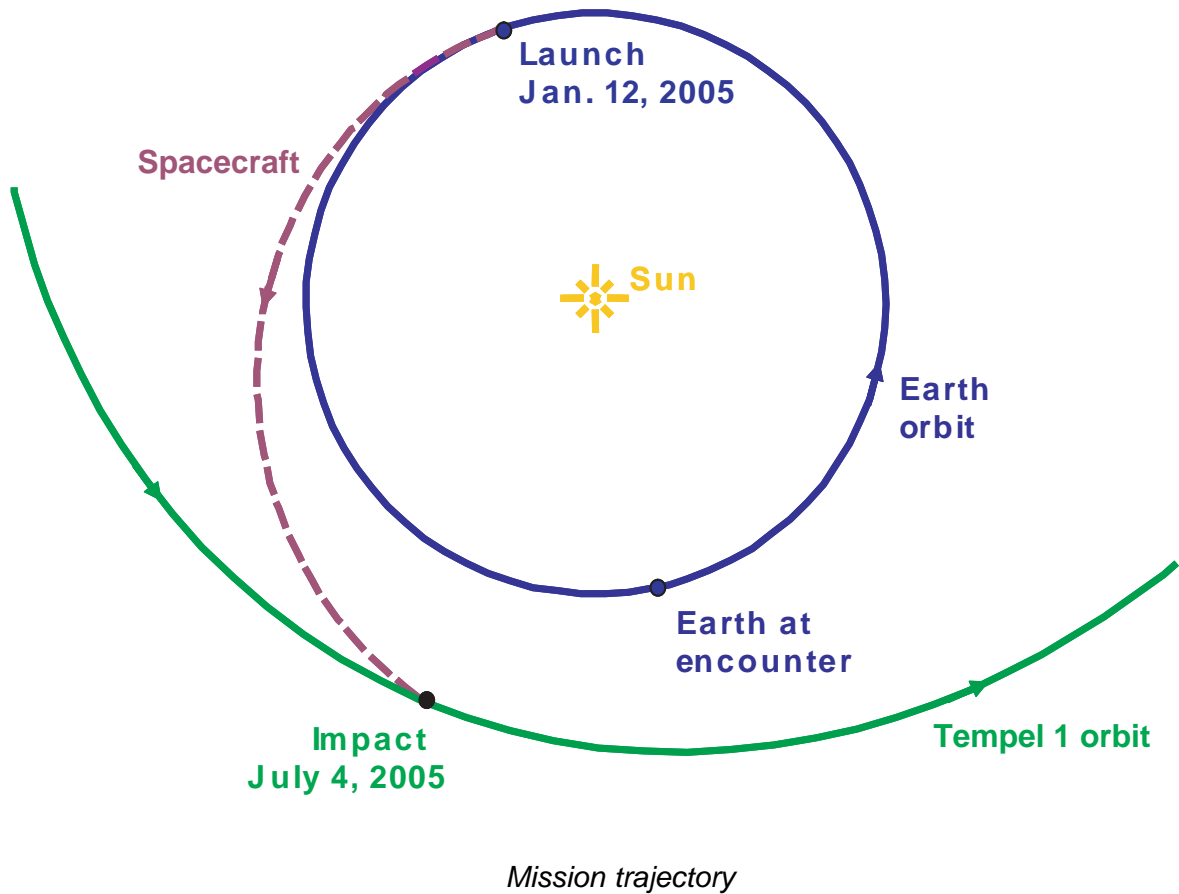

entific calibrations, an encounter demonstration test and readiness tests of ground systems.

### **Approach Phase**

The approach phase extends from 60 days before encounter until five days before encounter. Sixty days out roughly coincides with the earliest time that the team expected the spacecraft to be able to detect comet Tempel 1 in its medium-resolution camera. This milestone marked the beginning of an intensive period of observations to refine knowledge of the comet's orbit. Regular scientific observations are being used to study the comet's rotation, activity and dust environment.

### **Comet Encounter**

The encounter phase begins five days before and ends one day after the impact with comet Tempel 1. This brief but very intensive period includes two final targeting maneuvers, leading up to release of the impactor and its dramatic collision with the comet's nucleus. The encounter phase also includes imaging conducted by the flyby spacecraft during its close flyby of the nucleus, and transmission to Earth of all the flyby's collected data.

Both the Deep Impact spacecraft and comet Tempel 1 are in their own unique orbits around the Sun. However, the comet is traveling substantially faster (29.9 kilometers per second (66,880 miles per hour)) than the spacecraft (21.9 kilometers per second (48,990 miles per hour)). Just as the goal of a wide receiver in football is to arrive at the same location and time as the faster traveling ball thrown by the quarterback, Deep Impact's impactor needs to arrive at a certain point in space at the right time so that the comet actually runs over it at a relative velocity of 10.3 kilometers per second (about 23,000 miles per hour).

### **Trajectory Correction Maneuvers**

Beginning three weeks before the encounter, the mission team will focus on final targeting of the impactor. During this time, optical navigation images will be collected nearly continuously. These will be used to shape the final two trajectory correction maneuvers before the impactor is released. These two final thruster firings by the flyby spacecraft are designed to deliver the impactor precisely to the comet.

The first of these maneuvers will be conducted June 23, and will target the impactor at a window in space about 100 kilometers (62 miles) wide.

The last targeting maneuver is scheduled July 2, only 30 hours before encounter, or 6 hours before the impactor is released from the flyby spacecraft. This maneuver will shrink the target window to about 15 kilometers (9 miles) wide.

### **Impactor Release**

One day out from the comet, the flyby spacecraft will deploy the impactor. Before impactor release, the flyby spacecraft will adjust its orientation in space and configure itself for separation, including turning on heaters, arming separation actuators and enabling the impactor's battery. At the time of release, electrical disconnect actuators and separation pyros will fire, causing a spring to separate the two spacecraft at a speed of 34.8 centimeters per second (0.78 mph). Broken wires will verify that electrical disconnect took place.

### **Flyby Deflection Maneuver**

Shortly after separation, the flyby spacecraft will slew to a new orientation in space and fire its thrusters in what is called a deflection maneuver. This is designed to steer the flyby spacecraft away from the impactor just enough that it does not also collide with the comet or pass too close to potentially hazardous cometary particles surrounding the nucleus.

The maneuver begins 12 minutes after release of the impactor spacecraft, and lasts about 14 minutes. It will be the longest burn of the flyby spacecraft's thrusters up to

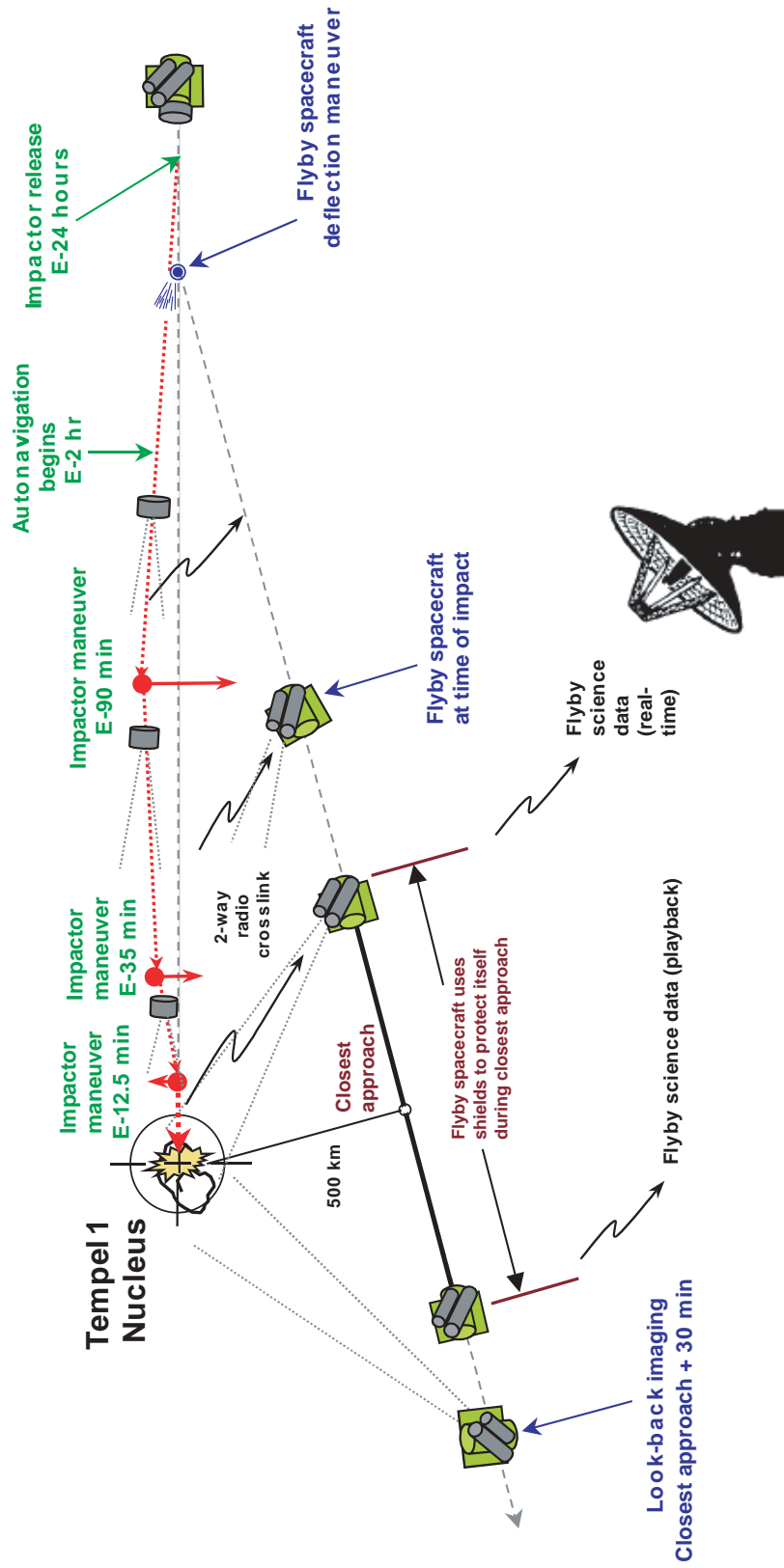

Encounter events

that time. The burn will slow the flyby spacecraft's speed by 102 meters per second (about 227 miles per hour). As a result, the flyby spacecraft will be 8,606 kilometers (5,348 miles) away from the impactor and comet at the time of impact. Because it is now traveling slower than the impactor, the flyby spacecraft will not make its closest approach to the comet nucleus until 14 minutes after the impact, passing within about 500 kilometers (310 miles).

### **Autonomous Navigation**

Due to the rapid pace of mission events leading up to the comet impact and the distance from Earth, both the flyby and impactor spacecraft were designed to perform automated onboard navigation, firing thrusters to change their orientation and flight path as necessary. Beginning two hours before impact, the "autonav" software on both flyby and impactor spacecraft will begin taking images of the comet nucleus at 15-second intervals. Autonav then performs image processing, orbit determination and maneuver computations. The autonav capability is based on heritage from the Deep Space 1 mission, which flew past comet Borrelly in 2001. Some of this capability was also used on the Stardust spacecraft to control pointing of observations of comet Wild 2 in January 2004.

### **Impactor Navigation**

During its 24 hours of free flight, the impactor will travel over half a million miles and maneuver itself directly into the path of the comet. The impactor will execute up to three thruster firings to fine-tune its flight path as it closes in on the comet nucleus. The first is scheduled 90 minutes before impact, followed by a second one 35 minutes before impact and a final firing 12.5 minutes before impact. The maneuvers will use four 22-newton thrusters firing in pulses varying in length from .015 to 0.5 second each.

The goal of the thruster firings is to aim the impactor to hit the comet in an unshaded area at a location easily observable by the flyby spacecraft.

### **Impactor Imaging**

The impactor begins science imaging 22 hours before impact with a pair of full-frame images -- one exposed for the nucleus, and one exposed for the coma, the dimmer cloud that surrounds the nucleus. Similar image pairs will then be obtained every two hours until 12 hours before impact. At that time, the impactor will spend two minutes taking the same pictures and other data that it will collect during the final two minutes before impact. This demonstration is designed to verify that it will execute this critical data-taking correctly during the final and most critical segment of its mission.

Beginning 10 hours before impact, images will be taken every two hours until 8 hours before impact; every hour from 7 to 4 hours before impact; and every 30 minutes from

## Encounter Events

<i>Event</i>	<i>Earth-received time (PDT)</i>	<i>Time relative to impact</i>
Optical navigation imaging increased to once per 9 minutes	6/29/05 11:00	-4 days
Trajectory correction maneuver	7/2/05 17:07	-29:45 hours
Impactor's battery activated	7/2/05 18:57	-27:55 hours
Impactor release	7/2/05 23:07	-23:45 hours
First telemetry from impactor, post-release	7/2/05 23:14	-23:38 hours
Flyby spacecraft executes divert maneuver	7/2/05 23:19	-23:33 hours
Flyby spacecraft executes divert trim maneuver (if required)	7/3/05 12:00	-11:52 hours
AutoNav system begins imaging	7/3/05 20:53	-1:59 hours
First impactor targeting maneuver	7/3/05 21:21	-91 min
Second impactor targeting maneuver	7/3/05 22:17	-35 min
Third impactor targeting maneuver	7/3/05 22:39	-13 min
<b>Impact</b>	<b>7/3/05 22:52</b>	
Flyby spacecraft enters shield mode	7/3/05 23:05	+13 min
Closest approach	7/3/05 23:06	+14 min
Flyby spacecraft turns to image departing comet for 24 hours more	7/3/05 23:51	+59 min

3 to 1 hour before impact. At that time, the pace of imaging will increase until it reaches a maximum of one picture every 0.7 second at about 12 seconds before impact. Engineers say that odds are at least 50-50 that dust hitting the impactor will end transmission of its images during the final 10 seconds before impact. The final potential image that could be transmitted in its entirety is one scheduled at about 2 seconds before impact, with a scale of about 20 centimeters (approximately 8 inches) per pixel.

## **Encounter Timing**

The impact with the comet on July 4, 2005 has been scheduled at 05:52 Universal Time -- late evening in the eastern Pacific region. This time has an uncertainty of 2 to 3 minutes. The time allows NASA's Deep Space Network complexes in both California and Australia to track the spacecraft. Besides allowing for fully redundant coverage by these two ground stations, the timing also permits the event to be observed by the major observatories at Mauna Kea on the island of Hawaii as well as at Palomar Observatory in California, Kitt Peak National Observatory in Arizona and other observatories in the southwestern continental United States and Baja California. The time also allows approximately 10 to 15 minutes of observation by Hubble Space Telescope before it moves behind Earth in its 90-minute orbit. Observations by other satellites will also be carried out during and/or shortly after the impact.

## **Impact**

Impact is scheduled to occur at 10:52 p.m. Pacific Daylight Time on July 3, 2005 (1:50 a.m. Eastern Daylight Time on July 4). There is a 2- to 3-minute uncertainty in the actual impact time, due to imperfect knowledge of the comet's path.

The kinetic energy released as the impactor smashes into the comet nucleus is expected to be 19 gigajoules -- similar to detonating 4.5 tons of TNT. The time it takes for the crater to form could vary, depending on the properties of the comet nucleus material, but is expected to be on the order of four minutes.

During the impact, the flyby spacecraft will train its high- and medium-resolution instruments on the predicted impact point. They will take pictures at a high rate beginning a few seconds before impact.

## **Shields Up! Shield Mode**

During most of the encounter phase before closest approach, the flyby spacecraft instruments will be pointed at the comet. The spacecraft will be protected by dust shields and oriented in a way to allow its cameras to continue taking pictures throughout the approach until it comes to within about 700 kilometers (420 miles) of the comet's nucleus. At this point, the spacecraft will stop taking pictures and fix its orientation so that its dust shields protect it as much as possible during the closest passage through the inner coma. Although comet imaging is not possible in the shield mode, pointing of the flyby spacecraft's high-gain antenna toward Earth is maintained during

this time, allowing the downlink of critical science data at the highest supportable data rate. The high-resolution instrument's infrared sensor will make a scan across the coma near the nucleus in the first few seconds after entering shield mode.

After entering shield mode, the spacecraft remains in this orientation until about 22 minutes after closest approach, when the dust-impact hazard zone has been safely passed.

### **Flyby Closest Approach**

The "miss distance" between flyby spacecraft and comet nucleus is planned for about 500 kilometers (311 miles). This distance was chosen to provide a survivable path through the comet's inner coma dust environment while still allowing a sufficiently close view of the crater by the spacecraft's high-resolution camera. The flyby spacecraft will make its closest approach to the comet nucleus 14 minutes and 10 seconds after the impact event.

Twenty-one minutes after the flyby spacecraft's closest approach to the comet nucleus, it will begin a maneuver to point its instruments back toward the nucleus. This maneuver takes about 9 minutes to complete. At that time, the first "look back" science data of the nucleus and its surroundings begins.

### **Post-Impact Flyby Data**

As the flyby spacecraft pulls away from the comet nucleus, it will use all of its instruments to monitor any new activity at the crater site. The rate of observations will gradually decrease as the comet becomes smaller in the instruments' fields of view. Ground-based telescopes will continue to monitor the comet for any later changes following the impact.

### **Playback Phase**

The playback phase begins one day after impact and continues until the end of mission 30 days after the cometary encounter -- or Aug. 3, 2005. Wrapping up the primary mission, data taken during the impact and subsequent crater formation will be transmitted to Earth. Backwards-looking observations of the departing comet will be continued for 60 hours after the impact to monitor changes in the comet's activity and to look for any large debris in temporary orbit around the nucleus.

### **Telecommunications**

Throughout the Deep Impact mission, tracking and telecommunications will be provided by NASA's Deep Space Network complexes in California's Mojave desert, near Madrid, Spain and near Canberra, Australia. Most data from the spacecraft will

return through the Deep Space Network's 34-meter-diameter (110-foot) antennas, but the 70-meter (230-foot) antennas will be used during some critical telecommunications phases.

## **Planetary Protection**

The United States is a signatory to the United Nations' 1967 Treaty on Principles Governing the Activities of States in the Exploration and Use of Outer Space, Including the Moon and Other Celestial Bodies. Also known as the "Outer Space Treaty," this document states in part that exploration of the Moon and other celestial bodies shall be conducted "so as to avoid their harmful contamination and also adverse changes in the environment of the Earth resulting from the introduction of extraterrestrial matter."

The policy that determines the restrictions applied in implementing the Outer Space Treaty is maintained by the International Council for Science's Committee on Space Research, which is headquartered in Paris. NASA's planetary protection policy adheres to the committee's policy, and provides for appropriate protections for solar system bodies such as comets.

For the Deep Impact mission, NASA's planetary protection officer has assigned a "Category II" status under the policy. This requires documentation of the mission and its encounter with Tempel 1, but places no additional operating restrictions on the mission. Comets are bodies that are of interest to the study of organic chemistry and the origin of life, but are not going to be contaminated by Earth-origin microorganisms.

It should also be noted that comets are exceedingly numerous in the solar system, and any particular comet has a finite lifetime. Indeed, Tempel 1 is a representative of a family of abundant comets. In this case, the benefits of the Deep Impact mission to cometary study far-outweigh any potential concerns about the fate of the comet itself.

## **Nom de Plumes to Help Make Cometary Plume**

Space fans worldwide may celebrate July 4, 2005, as the day their names reach a comet. The Deep Impact project sponsored a "Send Your Name to a Comet" campaign that invited people from around the world to submit their names via the Internet to fly onboard the Deep Impact impactor. A mini-compact disc bearing the names of more than half a million space enthusiasts is onboard Deep Impact. The mini-CD will melt, vaporize and essentially be obliterated -- along with everything else aboard the impactor -- when it collides with comet Tempel 1.

# Spacecraft

The Deep Impact flight system is actually two spacecraft mated together. One part, an impactor, will fly into the nucleus of comet Tempel 1. The second part, a flyby spacecraft, acts as the mother ship of the combo, carrying and powering the impactor until 24 hours before the comet impact. Each of these two spacecraft has its own instruments and capabilities to receive and transmit data.

Slightly less than half of the impactor spacecraft mass is composed of copper, a material chosen because it will not react rapidly with the water in the comet to produce compounds that would obscure the signals from the comet that will be studied by the mission's scientific instruments. For its short period of operation, the impactor uses simpler versions of the flyby spacecraft's hardware and software, and contains fewer backup systems.

## **Flyby Spacecraft**

The flyby spacecraft is about the size of an average mid-sized sport utility vehicle. It provides power, communications and maneuvering for both itself and the impactor while en route to the comet nucleus. It releases the impactor, receives impactor data, supports the instruments as they image the impact and resulting crater, and then transmits the scientific data back to Earth.

The flyby spacecraft is three-axis-stabilized, meaning that it does not spin as it flies through space and is able to continuously point the instruments at the comet. Its structure is constructed from aluminum and aluminum honeycomb. Blankets, surface radiators, finishes, and heaters passively control the temperature.

Most systems on the flyby spacecraft are redundant, meaning that there is a backup available if the main system encounters a problem. Automated onboard fault protection software will sense any unusual conditions and attempt to switch to backups. Both the flyby spacecraft and impactor will use onboard navigation software to find comet Tempel 1.

The spacecraft's main computer is based around a Rad 750 chip, a radiation-hardened version of a PowerPC processor used in various consumer computers. There are two redundant computers on the flyby spacecraft. Between them they have a total memory of 1,024 megabytes.

The flyby spacecraft uses an X-band radio to transmit to Earth at a frequency of about 8 gigahertz, and listens to the impactor on a different frequency. It is equipped with a single steerable, high-gain antenna and two fixed, low-gain antennas.

The spacecraft draws its power from a fixed solar array consisting of 7.5 square meters (about 80 square feet). A rechargeable 16-amp-hour nickel hydrogen battery provides power during one solar eclipse and while the solar array is directed away from the Sun.

To adjust its flight path through space, the flyby spacecraft has a propulsion system consisting of a group of thrusters. The fuel used by the thrusters is hydrazine.

### **Flyby Scientific Instruments**

The scientific instruments on Deep Impact's flyby spacecraft have two main purposes. During the first part of the mission, they guide the flyby spacecraft and impactor onto a collision course with the cometary nucleus. Then, during the mission's climax, they collect scientific observations before, during and after the impact. This includes observing material thrown off by the collision event, called "ejecta," as well as the crater created by the event and the surrounding area on the comet's nucleus.

The flyby spacecraft's two imaging instruments are mounted on a common platform. Each has a nine-position filter wheel that allows the science team to take pictures in different parts of the color spectrum.

❑ The **High-Resolution Instrument** is one of two imagers on the flyby spacecraft. It features a 30-centimeter-diameter (11.8-inch) telescope that delivers light simultaneously to both a multispectral camera and an infrared spectrometer. This camera is one of the largest instruments flown to date on a planetary mission. The instrument's camera will acquire images of the inside of the crater and obtain the best, most detailed pictures of a comet ever taken.

Tests after launch indicated that the imager's focus was not as expected. Although the focus has improved after the instrument was heated, or "baked out," to remove normal residual moisture, spatial resolution remains a factor of 3 to 4 less than planned. A "tiger team" of engineers found that the most likely cause of the problem was a mirror that, while flat at room temperature, developed some curvature at the cryogenic temperatures of the thermal-vacuum tests. The team will compensate by using an image processing technique called deconvolution which was also used to improve images from the Hubble Space Telescope before its second camera instrument was installed. The science team is confident that the technique will allow them to recover resolution essentially the same as what was planned before launch.

❑ The **Medium-Resolution Instrument** is the other scientific instrument on the flyby spacecraft. This instrument takes pictures of stars and the comet for guidance and navigation. It also collects visible images with a wide field-of-view of material ejected from the comet as well as the comet nucleus itself for



## Impactor

The impactor spacecraft weighs a total of 372 kilograms (820 pounds), with 113 kilograms (249 pounds) of that being "cratering mass" -- dead weight designed to help the impactor make a substantial crater in the cometary nucleus. The cratering mass is made up of copper plates at the impact end of the impactor. The copper plates are machined to form a spherical shape.

The impactor is powered during its brief solo flight by a single 250-amp-hour battery. The computer and avionics interface box are similar to those on the flyby spacecraft; star trackers, inertial reference units and many propellant subsystem components are the same on both spacecraft. Like the flyby spacecraft, the impactor has a group of thrusters to refine its flight path. Because of its brief mission, the impactor does not have redundant backups as does the flyby spacecraft.

The impactor's single scientific instrument, called the **Impactor Targeting Sensor**, is an imaging system identical to the medium-resolution instrument on the flyby spacecraft, but without a filter wheel. A 12-centimeter-diameter (4.7-inch) telescope provides navigation images as well as closeup scientific images of the comet just before impact. The best resolution expected from this instrument is about 20 centimeters (approximately 8 inches) per pixel when the impactor is 20 kilometers (about 12 miles) away from the comet's nucleus -- although the dust surrounding the comet is likely to sand-blast the mirror significantly in the last half minute or so. Dust impacts may also disturb the instrument's pointing in the final minute before impact.

# Science Objectives

The primary goal of the Deep Impact mission is to explore the interior of Comet Tempel 1 by using an impactor to excavate a crater in the comet's surface, after which the flyby spacecraft will take data on the newly exposed cometary interior and the comet material ejected from the crater. Scientists believe in-depth analysis of this new view of Tempel 1 will reveal a great deal not only about this comet but also the role of comets in the earliest history of the solar system.

In particular, the mission's scientific objectives are to:

- Dramatically improve the knowledge of key properties of a cometary nucleus and, for the first time, directly assess the interior of a cometary nucleus by means of a massive impactor hitting the surface of the nucleus at high velocity.
- Determine properties of the comet's surface layers such as density, strength, composition and how porous it is.
- Study the relationship between the surface layers of the comet's nucleus and the possibly pristine materials of the interior by comparing the interior of the crater with the pre-impact surface.
- Improve our understanding of the evolution of cometary nuclei by comparing the interior and surface.

The main scientific investigation is to understand the differences between the interior of a cometary nucleus and its surface. Some of the questions that will be addressed are:

- If the crater depth reaches 20 meters (about 60 feet), do the ices suddenly become carbon monoxide or carbon dioxide ice instead of water ice?
- Or, is the ice still predominantly water (H<sub>2</sub>O)? If water ice, is its structure crystalline or amorphous?
- Is the mantle devoid of volatile materials? To what depth?
- Is the comet's structure homogeneous from side to side on various scales?
- How does the ratio of ice to refractory (non-melting) material change?
- How old is the surface?
- Does the mantle seal off vaporization from certain areas? Or are certain areas just more devoid of volatile materials than others?
- Where will future missions have to go to really sample primordial material?

## Science Team

Dr. Michael A'Hearn, University of Maryland, *Principal Investigator*

Michael J. S. Belton, Belton Space Exploration Initiatives, *Deputy Principal Investigator*

### *Co-Investigators:*

Alan Delamere, Delamere Support Services

Jochen Kissel, Max-Planck-Institut für Aeronomie

Kenneth P. Klaasen, Jet Propulsion Laboratory

Lucy McFadden, University of Maryland

Karen J. Meech, University of Hawaii

H. Jay Melosh, University of Arizona

Peter H. Schultz, Brown University

Jessica M. Sunshine, Science Applications International Corp.

Peter C. Thomas, Cornell University

Joseph Veverka, Cornell University

Donald K. Yeomans, Jet Propulsion Laboratory

As a secondary investigation, Deep Impact will look at the question of whether comets become dormant or extinct as they evolve. If comets tend to become dormant, then the outer layers of the nucleus have hardened over time, trapping ice in the interior. In this case, the impactor may break through these outer layers, reactivating the area. On the other hand, if comets tend to become extinct, then an area stays active until all of the ice is gone. In that case, even an impactor the size of Deep Impact's will not reactivate the area. Since Tempel 1 is a relatively inactive comet, it provides a good opportunity to study this issue.

### **Deep Impact's Crater**

Though they know that the collision event will create a roughly circular crater on the comet nucleus' surface, scientists do not know what size and type of crater will form. There are three likely scenarios that the crater formation can take.

❑ In the first scenario, the crater formation is governed mostly by the gravity of the cometary nucleus (known as a "**gravity-dominated**" process). In this case, the cone of ejected material spreads outwards at an angle of around 45 to 50 degrees from the surface of the comet. The cone's base remains attached to the cometary nucleus. The majority (roughly 75 percent) of the material will fall back down onto the surface of the comet, forming a large-diameter ejecta blanket. In this model, the crater may be as large as a football stadium (around 200 meters or roughly 650 feet in diameter), and 30 to 50 meters (about 100 to 150 feet) deep.

❑ The second possibility is that the more dominant resisting force of the crater formation is the strength of the material (known as a "**strength-dominated**" process). In this case, the ejecta cone will be at a higher angle (around 60 degrees). The cone's base will detach from the crater, and may detach from the comet entirely. Less material (around 50 percent) will fall back to the surface of the comet in this scenario, leaving a smaller ejecta blanket. In this model, the crater will be much smaller, on the order of 10 meters (roughly 30 feet) or less. Predictions of the volume of ejecta produced differ by a factor of a thousand.

❑ A third possibility is that the cometary material is so porous that most of the impactor's energy and momentum are absorbed in the process of compression and heating (known as a "**compression-dominated**" process). Since so much energy is used in compression, there is less available for excavation, and the result is a much smaller diameter crater than expected. In this scenario, the crater will be deep, but produce a very small ejecta cone.

The cratering process will help reveal what type of material makes up the nucleus (or at least the outer layer), and therefore how the comet formed and evolved. If the crater turns out to be gravity-dominated, this lends evidence to the theory that the comet's nucleus consists of porous, pristine, unprocessed material, and that the comet formed by accretion.

If, however, the crater turns out to be strength-dominated, then this suggests that the material of the nucleus is processed somehow, resulting in a comet that can hold together better under impact. This would mean that it is not the pristine, untouched material of accretion. It's also possible that the initial crater formation will be strength-dominated, suggesting a processed outer shell to the nucleus, but that the bulk of the crater is gravity-dominated, suggesting that the impactor has punched through this outer shell into the pristine material below.

Scientists also hope that observing the radius of the ejecta plume and the speed with which the plume changes over time will give them a better estimate of the nucleus material's density. Since the comet's volume will be known, an estimate of density allows for an estimate of the comet's mass.

### **Other Eyes in the Sky**

Along with the Deep Impact flyby spacecraft, there will be numerous other space-borne "sets of eyes" watching the events unfold around comet Tempel 1. The Deep Impact team will use these space-based observations to complement the data taken by the spacecraft.

❑ The **Hubble Space Telescope** is assisting in the determination of comet Tempel 1's orientation and the existence of any jets leading up to July 4th encounter. It will perform spectroscopic observations and imagery at the time of impact. The Hubble Space Telescope is managed by the Space Telescope Science Institute, Baltimore, Md., for the Science Mission Directorate, NASA Headquarters, Washington.

❑ **Chandra X-Ray Observatory** will look for the emission of X-rays during the comet encounter. The Chandra X-ray Observatory program is managed by NASA's Marshall Center, Huntsville, Ala., for the Science Mission Directorate, NASA Headquarters, Washington.

❑ The **Spitzer Space Telescope** will observe the comet before, during and after impact in infrared light. It will look for traces of the materials that make up the interior of the comet by monitoring changes in the chemical composition of the comet's coma. Spitzer is managed by NASA's Jet Propulsion Laboratory for the Science Mission Directorate, NASA Headquarters, Washington.

❑ The **Galaxy Evolution Explorer** will use ultraviolet wavelengths to watch for changes in carbon monoxide and carbon dioxide before, during and after encounter. The mission is managed by JPL for the Science Mission Directorate, NASA Headquarters, Washington.

❑ The European Space Agency's **Rosetta** spacecraft will turn its suite of four remote-sensing instruments in the direction of Tempel 1. Included in these sensors is a NASA microwave instrument that will measure for the comet's water signature before and after impact. Also, an ultraviolet imaging spectrometer provided by NASA will analyze gases in the coma and tail and measures the comet's production rates of water, carbon monoxide and carbon dioxide.

❑ The **Submillimeter Wave Astronomy Satellite** will be observing the comet during the months of June and July to monitor for any change in water production before, during and after the impact. The mission is managed by NASA's Goddard Space Flight Center, Greenbelt, Md., for the Science Mission Directorate, NASA Headquarters, Washington.

## **Big Eyes on the Ground**

Also assisting the Deep Impact team are several teams of Earth-based astronomers that will make more than 30 ground-based observations to complement the data taken by spacecraft.

During the encounter, comet Tempel 1 will be in the late twilight sky in the Hawaiian Islands, making them an ideal location for ground-based observations. Observatories

atop Mauna Kea will monitor venting from the comet nucleus during the impact event. Among them will be the world's two largest telescopes, the 10-meter-diameter (33-foot) Keck 1 and Keck 2 telescopes. The W. M. Keck Observatory is run by the California Association for Research in Astronomy, a nonprofit scientific partnership between the California Institute of Technology, the University of California and NASA.

Other major observatories watching during moment of encounter include Palomar Observatory in California, Kitt Peak National Observatory in Arizona and many other telescopes in the southwestern United States and in Baja California.

### **Small Telescope Science Program**

The Deep Impact project has organized a small telescope science program, calling on technically proficient amateurs to supplement observations by large observatories. The Small Telescope Science Program is a collaborative effort among advanced observers, private observatories and professional astronomers around the world to gather ground-based optical data on comet Tempel 1. The main objective is to provide continuous monitoring of Tempel 1 to complement periodic observations by large telescopes. Details on how observers can participate are available at [deepimpact.umd.edu/stsp](http://deepimpact.umd.edu/stsp) .

### **Watching During the Night of the Comet**

Amateur astronomers and others not participating in the formal scientific program may be able to get a look at comet Tempel 1 if they have access to a small telescope -- or, possibly with a large set of binoculars. During June 2005, the comet brightens as it continues to approach the Sun and Earth. From that point forward until the collision event, it will appear in the evening sky in the constellation of Virgo.

In all but the Pacific coast of the continental United States, comet Tempel 1 will be below the horizon during the encounter and therefore not visible. Moving west to the Pacific coast, it will be just above the southwest horizon.

If it weren't for the Deep Impact mission, the comet would only reach a magnitude of about 9.5. The limit of the unaided human eye is about magnitude 6 (larger numbers mean dimmer objects), so some form of telescope or powerful binoculars would be necessary. But the impact could make the comet 15 to 40 times brighter than normal -- perhaps as bright as 6th magnitude, around the limit of the human unaided eye. The comet's position and orbit are listed on NASA's Near-Earth Object website at [neo.jpl.nasa.gov](http://neo.jpl.nasa.gov) .

# Comet Cratering 101

An impact crater is a hole excavated out of a surface -- for example, a planet, moon, asteroid or comet -- when a smaller mass moving at very high speed collides with it.

## How do impact craters form?

When an impactor strikes a target, the energy it releases is proportional to its mass and the square of its velocity. So even small objects can release a lot of energy if they are traveling fast. For example, Deep Impact's impactor weighs 370 kilograms (816 pounds), and will be traveling at a velocity of 10.3 kilometers per second (about 23,000 miles per hour). Its kinetic energy will be 19 gigajoules -- about the equivalent of the amount of energy released by exploding 4.5 tons of TNT, or roughly the amount of energy used in an average American house in one month.

Physics tells us that the total amount of energy is conserved when two bodies strike each other. The energy, therefore, can't be lost, but only transferred. The large amount of energy causes several things to happen:

- Some of the material from both impactor and target will be melted or even vaporized by the tremendous amount of heat generated by the impact. (The impactor is destroyed during the impact, but only a small amount of matter will be lost through conversion to energy).
- A great deal of the energy and momentum will go into moving the material that the comet nucleus is made of -- part of which is driven downward, the rest of which will be ejected from the crater site
- A shock wave will pass through both the impactor and the target
- Some "endothermic" chemical reactions -- ones that require energy -- may be driven to occur, if they can happen fast enough before the heat dissipates

Crater formation takes place in three stages:

**1. Compression Stage:** The impactor punches a (relatively) small hole in the target, and a shock wave begins to pass through the target. The impactor's energy is converted into heat and kinetic energy in the target; pressure generated by the impact is so great that even solid material can act somewhat fluidly, flowing away from the impact site. There is very little material ejected up and out of the forming crater during

*(continued on next page)*

*(continued from previous page)*

this stage, although a plume of impact-generated vapor rapidly expands above the crater. This stage is very quick, lasting an amount of time dictated by the impactor's diameter divided by its speed at impact. For Deep Impact, this stage will last only around 100 microseconds.

The compression stage of crater formation is over so fast for the Deep Impact collision that it is very unlikely that there will be any data gathered, although the brightness of the flash may provide information about surface materials on the comet nucleus. Most of the imaging and spectroscopy will occur during later stages.

**2. Excavation Stage:** The shock wave that began in the compression stage continues to move outward through the target body's material. Interestingly, this wave spreads out from a point below the surface of the target. As a result, the wave actually spreads upwards from the impactor, and sends some of the target material up and out from the impact site. This material is referred to as "ejecta." Initially the ejecta forms a plume of hot vapor, melt droplets and fine debris. Then a cone-shaped curtain of material spreads upwards from the impact site. Some or all of this ejecta will land in the area surrounding the crater, forming an ejecta blanket. The crater itself grows very large very quickly during this stage, and material at the lip of the crater folds over creating a rim. Fractures often spread down into the target from the crater site as well. This stage is longer than the compression stage. For Deep Impact, this stage will last around 300 seconds.

**3. Modification Stage:** Loose debris from the impact will tend to slide down the steep crater walls. Some loosened material may slip in sheets, forming terraces along the crater sides. In some craters, a central peak may form as some of the target material splashes back upwards at the initial point of impact. This stage lasts about the same amount of time as the excavation stage -- although of course the crater can be further modified by erosion, later impacts, lava flows or tectonic activity for millions of years afterwards depending on conditions on the target. For Deep Impact, this stage is not very important, since the low gravity on the comet will probably only cause some small amount of collapse near the rim. There will not be the uplift that can be seen in larger craters, so there will be no central peak.

### **What will the Deep Impact spacecraft detect during this collision?**

What exactly will be seen during the excavation stage is a matter of some debate, and is actually one of the questions that this mission will answer. There are some certainties. It is known, for example, that impacts at this velocity always form circular craters, so we know the crater will be circular. We also know that there will be some ejecta, since that follows along with the impact.

# Program/Project Management

Led by principal investigator Dr. Michael A'Hearn of the University of Maryland, College Park, Md., the Deep Impact mission is managed by the Jet Propulsion Laboratory, Pasadena, Calif., for NASA's Science Mission Directorate, Washington.

At NASA Headquarters, Alphonso V. Diaz is associate administrator for the Science Mission Directorate. Andrew Dantzler is director of the Solar System Division. Steve Brody is program executive for the Discovery Program, Lindley Johnson is Deep Impact program executive, and Dr. Thomas Morgan is Deep Impact program scientist.

At the Jet Propulsion Laboratory, Rick Grammier is project manager. Keyur Patel is deputy program manager, and David Spencer is mission manager. JPL is a division of the California Institute of Technology, Pasadena, Calif.

Ball Aerospace & Technologies Corp., Boulder, Colo., designed and built the spacecraft. Monte Henderson is the company's Deep Impact program manager.

6-28-05